

Flokk AS
Drammensveien 145
P.O. Box 45 Skoyen
0202 Oslo
Norway

Fürth, October 14/2021

TEST REPORT No. FUHLFP2021-04842-M-2

The test report is modified test report of FUHLFP2021-04841 M

Date sample received: June 01/2021

Period of testing: July 12/2021 – August 31/2021, September 15/2021, October 14/2021

Technical Director: Kerstin Scharrer

Test Item: Office work chair HÅG SoFi model Mod. 7500

Test: General safety tests to EN 1335-1:2020 and EN 1335-2:2018 to achieve the GS Mark

Determination:

The test sample "HÅG SoFi 7500" was submitted for the general safety tests to EN 1335-1:2020 and EN 1335-2:2018, considering the current state of the art.

In summary, the test requirements **were fulfilled**.

Please refer to the following pages for technical characteristics and results as well as detailed test conditions and requirements.

Reviewed by:
Intertek Consumer Goods GmbH

Manager Hardlines
Frank Urbich

Tested by:
Intertek Consumer Goods GmbH

Technical Expert
Jai Kiran Kumar Galla

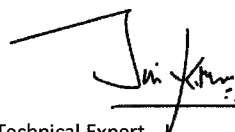

21/10-21
UR

Product identification:

Test sample:	Office work chair
Model name:	HÅG SoFi
Item number:	7500
Manufacturer:	Flokk AS, Sundveien 201, 7374 Roros, Norway
Number of test samples:	1 sample of 7500
Distributor:	Flokk
Delivered on:	01.06.2020
Delivered by:	Flokk

Product documents:

User Guide, Product specification sheet and Product marking

Scope of the investigations:

EN 1335-1:2020, Office furniture - Office work chair –
Part 1: Dimensions - Determination of dimensions

EN 1335-2:2018, Office furniture - Office work chair –
Part 2: Safety requirements

Abbreviations:

*	=	Test method is not part of the accreditation scope
**	=	Outsourcing
n.a.	=	not applicable
n.t.	=	not tested
n.d.	=	not determinable (< LoQ)
LoQ	=	limit of quantification
CS	=	Combined sample
P	=	passed
F	=	failed

Applicability of measurements:

The test results refer only to the objects to be tested. The digital images in this report are intended as supplementary information and are not an integral part of this test report.



Test equipment list

The test equipment list contains a list of the measuring tools used and measuring equipment, gauges, templates and load weights that were used in accordance with the scope of the investigations.

Testing machines and devices as well as any connections that are necessary for the performance of tests are not an integral part of the test equipment list.

The following test equipment were available for testing in accordance with the scope of the investigations:

Clause	Test equipment	Equipment no.
General tests	Ruler	PM_HL_18.321
General tests	Band ruler 3000 mm	PM_HL_18.367
General tests	Calliper	PM_HL_17.044
Strength and durability tests	Load cell 5 kN	PM_HL_18.358
Strength and durability tests	Load cell 5kN	PM_HL_18.359
Strength and durability tests	Load cell 5kN	PM_HL_18.360
Strength and durability tests	Load cell 5 kN	PM_HL_18.361
Strength and durability tests	Load cell 2 kN	PM_HL_18.362
Strength and durability tests	Load cell 5,5 kN	PM_HL_18.363
Strength and durability tests	Seat dummy	PM_HL_18.199
Stability	Pull-Push-Gauge	PM_HL_17.026
Stability	Stability Table	PM_HL_18.107
Stability	Load disc 10 Kg	PM_HL_18.231
Stability	Load disc 10 Kg	PM_HL_18.232
Stability	Load disc 10 Kg	PM_HL_18.233
Stability	Load disc 10 Kg	PM_HL_18.234
Stability	Load disc 10 Kg	PM_HL_18.235
Stability	Load disc (wood)	PM_HL_18.216
Stability	Load disc (wood)	PM_HL_18.217
Stability	Load disc (wood)	PM_HL_18.218
Stability	Load disc (wood)	PM_HL_18.219
Stability	Load disc (wood)	PM_HL_18.220
Stability	Load disc (wood)	PM_HL_18.221
Stability	Load disc (wood)	PM_HL_18.222
Stability	Load disc (wood)	PM_HL_18.223
Stability	Load disc (wood)	PM_HL_18.224
Stability	Load disc (wood)	PM_HL_18.225
Stability	Load disc (wood)	PM_HL_18.226
Stability	Load disc (wood)	PM_HL_18.227
Stability	Load disc (wood)	PM_HL_18.228
Stability	Load disc (wood)	PM_HL_18.229
Loading point template - A-B	Measurement template	PM_HL_18.109
Strength and durability tests	Durability test stand	PM_HL_18.153
Strength and durability tests for castor	Linear axis test stand	PM_HL_18.066



General Testing

Technical characteristics

General dimensions

Model	7500
Depth (mm):	730
Height (mm):	1115-1165
Width (mm):	730
Net weight (kg):	17.0

Brief description of the sample

Office work chair with/without armrest, including following features:

- Textile mesh chair back
- Seat height adjustable by means of gas spring (class 4, S.C. Stabilus Romania S.R.L.)
- Adjustable lumbar support
- Five star aluminium base (730mm) available in black, silver or white, optionally in polished aluminium
- Adjustable tilting resistance forwards and backwards
- Armrest traverse with slide back function

Mod. 7500: with aluminium armrests and mesh back, high backrest



Photo documentation – mod. 7500



Measurement table for chair EN 1335-1 TYPE A

Dimensional requirements

Measurements	Symbol	Type A – Requirements in mm					Actual result	Verdict
		Allow \ominus	min.	max.	Allow \oplus	minimum range		
Office chair:								
Seat height and sitting height ^x	<i>a^{a,b}</i>	yes	400	520	yes	130	403 mm – 547 mm (range: 144 mm)	P
Adjustable depth of the seat	<i>b</i>	yes	425	450	yes	70	409 mm – 485 mm (range:76 mm)	P
Fixed depth of the seat		no					/	n.a.
Adjustable height of lumbar support	<i>f</i>	yes	170	300	yes	-	180 mm – 300 mm (range: 120 mm)	P
Fixed height of lumbar support		no					/	n.a.
Maximum distance from the backrest to the front of the armrests	<i>q^c</i>	yes	-	300	no	-	197 mm	P
Hip breadth clearance when armrests are in widest position	<i>r^d</i>	no	480	-	yes	-	540 mm	P
Adjustable clear distance between armrest pads	<i>z^{d,e}</i>	yes	410	510	yes	-	401 mm – 512 mm (range: 111 mm)	P
Fixed clear distance between armrest pads		no					/	/
Height of armrests adjustable	<i>p</i>	Yes	200	290	yes	100	195 mm – 305 mm (range 110 mm)	P
Height of armrests not adjustable		no					/	/
Seat pad width	<i>d</i>	no	400	-	yes	-	424 mm	P
Seat pad depth	<i>c</i>	no	380	-	yes	-	428 mm	P
Backrest height	<i>h</i>	no	360	-	Yes	-	590 mm	P
Backrest width	<i>j</i>	no	360	-	yes	-	390 mm	P
Radius of backrest	<i>k</i>	no	400	-	yes	-	> 400 mm	P
Armrest length	<i>n</i>	no	150	-	yes	-	235 mm	P
Armrest width	<i>o</i>	no	40	-	yes	-	86 mm	P
Offset of the underframe	<i>s</i>	yes	-	415	no	-	400 mm	P

a For tall office work chairs the seat height is determined as the vertical distance measured at the front of the seat, from the loaded seat to the floor

or top of the foot support. The foot support shall have a minimum diameter of 20 mm or be flat.

b Sitting height is only applicable for chairs with seat pad angles less than 0 (rearwards slope).

c The distance q shall be measured when the minimum usable armrest area template, 150 mm x 50 mm (Type Ax and Type A) or 150 mm x 40 mm

(Type B and Type C), are parallel to the median plane (see 3.9) of the seat.

d The gap shall be retained across the height adjustment range of the armrests for functional fit.

e The clear distance 'z' shall be measured when the minimum usable armrest area templates, 150 mm x 50 mm (Type Ax and Type A) or 150 mm x

40 mm (Type B and Type C), are parallel to the median plane of the seat.

Column "Allow \ominus ": If there is a "yes", dimensions less than the minimum requirement are accepted. If there is a "no", the dimension shall not be less than the minimum required dimension

Column "Allow \oplus ": If there is a "yes", dimensions more than the maximum dimension requirement are accepted. If there is a "no", the dimension shall not be more than the maximum required dimension.

Angle requirements Type A

Measurements	Symbol	Type A – Requirements in °					Actual result	Verdict
Office chair:		Allow ⊖	min.	max.	Allow ⊕	minimum range		
Angle between seat and back	$\gamma^{a,b}$	no	90	-	yes	-	95.2° - 97.8° (range:2.6°)	P
Backrest inclination range	l	min. 15					22,6°	P
Seat pad angle adjustable	e ^b	yes	-2	-	yes	-	- 15,3° /+ 13,6°	P
Minimum adjustment range		min. 5					28.9°	P
Seat pad angle fixed		no	+2	-7	no	-	/	n.a.

a As long as it is possible to achieve an angle of minimum 90° between seat pad and backrest, the requirement is fulfilled.

b The adjustment range shall include the specified seat pad angle.

Column "Allow ⊖" If there is a "yes", dimensions less than the minimum requirement are accepted. If there is a "no", the dimension shall not be less than the minimum required dimension

Column "Allow ⊕": If there is a "yes", dimensions more than the maximum dimension requirement are accepted. If there is a "no", the dimension shall not be more than the maximum required dimension

Test characteristics/requirements	Test parameters/results	Verdict
<p>Safety requirements in accordance to EN 1335-2</p> <p>General design requirements</p> <p>Corners and edges, trapping, pinching and shearing</p> <p>The chair shall be so designed as to minimise the risk of injury to the user.</p> <p>All parts of the chair with which the user comes into contact during intended use, shall be so designed that physical injury and damage to property are avoided.</p> <p>These requirements are met when:</p> <p>a) the safety distance of accessible movable parts is either ≤ 8 mm or ≥ 25 mm in any position during movement;</p> <p>b) accessible corners are rounded with minimum 2 mm radius;</p> <p>c) the edges of the seat, back rest and arm rests which are in contact with the user when sitting in the chair are rounded with minimum 2 mm radius;</p> <p>d) the edges of handles are rounded with minimum 2 mm radius in the direction of the force applied;</p> <p>e) all other edges are free from burrs and rounded or chamfered;</p> <p>f) the ends of accessible hollow components are closed or capped.</p> <p>Adjusting devices</p> <p>Movable and adjustable parts shall be designed so that injuries and inadvertent operation are avoided.</p> <p>It shall be possible to operate the adjusting devices from sitting position in the chair.</p> <p>Connections</p> <p>It shall not be possible for any load bearing part of the chair to come loose unintentionally.</p>	<p>no risk of injury</p> <p>fulfilled</p> <p>no distances between moveable parts of ≤ 8 mm or ≥ 25 mm</p> <p>accessible corners are rounded with 2 mm</p> <p>accessible edges are rounded with 2 mm</p> <p>no handle</p> <p>all other edges free of burrs</p> <p>no free open ends</p> <p>Injuries are avoided during operation</p> <p>Possibility given</p> <p>no load bearing parts possible to become loose unintentionally</p>	<p>P</p> <p>P</p> <p>P</p> <p>P</p> <p>n.a.</p> <p>P</p> <p>P</p> <p>n.a.</p> <p>P</p> <p>P</p>
<p>Remark: Test results has been taken from report no. FUHL2020-01988</p>		



intertek

Total Quality. Assured.

Intertek Consumer Goods GmbH
Würzburger Straße 152
90766 Fürth, Germany

Tel.: +49 911 74075 0
Fax: +49 911 74075 30
cg.germany@intertek.com

Location Fürth
Amtsgericht Fürth, HRB 5756
USt-IdNr. DE169317871

Managing Director
Reinhold Gehling

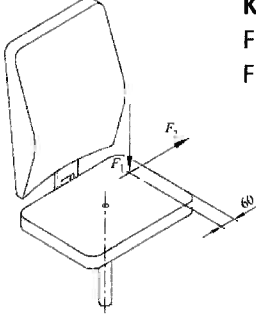

Test characteristics/requirements	Test parameters/results	Verdict
<p>Sideways overturning for chairs without armrests</p> <p>Position the chair with two adjacent supporting points on one side against the stops.</p> <p>Apply by means of the stability loading device a vertical force F1 acting 60 mm from the side edge of the load bearing structure of the seat at those points most likely to result in overturning. Apply for at least 5 s a horizontal sideways force F2 outwards from the point on the seat surface where the vertical force is applied, (see Figure 9).</p> <div style="text-align: center;">  <p>Key F1 vertical force F2 horizontal force</p> </div> <p>Figure 9 — Sideways overturning for chairs without armrests</p>	<p>No overbalancing by F1 = 600 N F2 ≥ 20 N</p>	<p>n.a.</p>

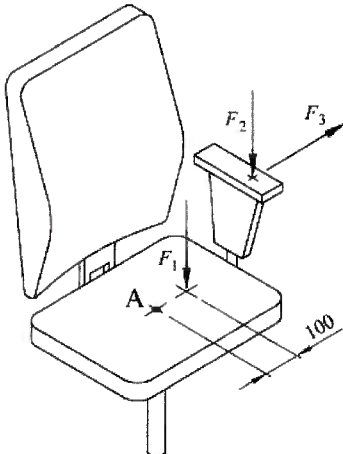
Test characteristics/requirements	Test parameters/results	Verdict
<p>Sideways overturning for chairs with armrests</p> <p>Position the chair with two adjacent supporting points on one side against the stops.</p> <p>Apply by means of the stability loading device a vertical force F_1 acting at a point 100 mm from the fore and aft centre line of the seat at the side where the supporting points are restrained (see Figure 10) and between 175 mm and 250 mm forward of the rear edge of the seat.</p> <p>Apply a vertical downward force F_2 acting at points on the arm rest which is on the same side as the restrained supporting points up to a maximum 40 mm inwards from the outer edge of the upper surface of the arm rest, but not beyond the centre of the arm rest, and at the most adverse position along its length. Apply a horizontal sideways force F_3 outwards from the same point for at least 5 s (see Figure 10).</p> <p style="text-align: right;">Dimensions in millimetres</p>  <p>Key A seat loading point F_1 vertical force F_2 vertical force F_3 horizontal force</p> <p>Figure 10 — Sideways overturning for chairs with armrests</p>	<p>No overbalancing by $F_1 = 250 \text{ N}$ $F_2 = 350 \text{ N}$ $F_3 \geq 35 \text{ N}$ (required $F_3 \geq 20 \text{ N}$)</p>	<p>P *)</p>
<p>*) Test result based on mod. with armrests</p>		

Test characteristics/requirements	Test parameters/results	Verdict
<p>The unloaded chair shall not roll unintentionally.</p> <p>This requirement is met when:</p> <p>a) the castors are of identical construction;</p> <p>b) the rolling resistance is ≥ 12 N when tested according to Rolling resistance of the unloaded chair.</p> <p>Rolling resistance of the unloaded chair</p> <p>The chair shall be placed on the test surface and shall be pushed or pulled over a distance of at least 550 mm. A speed of (50 ± 5) mm/s shall be maintained over the measuring distance. The force shall be applied at a height of (200 ± 50) mm above the test surface.</p> <p>Record the force used to push or to pull the chair over the distance from 250 mm to 500 mm as the rolling resistance.</p> <p>Rearwards overturning for chairs without back rest inclination</p> <p>Position the chair with two adjacent supporting points on the back against the stops. When an independent lumbar adjustment is fitted it shall be set in the most adverse configuration.</p> <p>A vertical force F1 shall be applied at point "A" and a horizontal force F2 shall be applied at point "B", (see Figure 11).</p> <p>If the back rest pad is pivoting around a horizontal axis above the height of the seat and is free to move, the horizontal force shall be applied on the axis. If height adjustable, the axis shall be set as close as possible to 300 mm above point "A".</p>	<p>Push and pull force ≥ 15 N</p> <p>See above</p> <p>No overbalancing</p>	<p>P</p> <p>P</p>

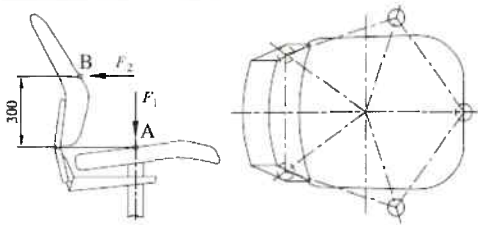
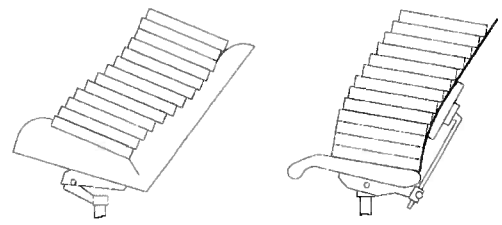

Test characteristics/requirements	Test parameters/results	Verdict
 <p>Key</p> <ul style="list-style-type: none"> A seat loading point (6.1) B back loading point (6.2) F₁ vertical force F₂ horizontal force <p>Figure 11 — Rearward overturning for chairs without back rest inclination</p> <p>Rearwards overturning for chairs with adjustable back rest inclination</p> <p>Do not position the chair with the supporting points against the stops. When an independent lumbar adjustment is fitted it shall be set in the most adverse configuration.</p> <p>Load the chair with discs so that the discs are firmly settled against the back rest (see Figure 12). If the height of the stack of discs exceeds the height of the back rest, prevent the upper discs from sliding off by the use of a light support.</p>  <p>Figure 12 — Rearward overturning for chairs with adjustable back rest inclination</p>	<p>No overbalancing by 13 discs</p>	<p>P</p>

Test characteristics/requirements	Test parameters/results	Verdict
<p>Strength and durability</p> <p>The chair shall be constructed to ensure that it does not create a risk of injury to the user of the chair under the following conditions:</p> <p>a) sitting on the seat, both centrally and off-centre;</p> <p>b) moving forward, backwards, and sideways while sitting in the chair;</p> <p>c) leaning over the armrests;</p> <p>d) pressing down on the arm rests while getting up from the chair.</p> <p>These requirements are fulfilled when after the tests specified in Seat front edge static load test, Combined seat and back static load test, Foot rest static load test, Seat and back durability and Armrest durability with the forces and numbers of cycles according to Table 2 of this standard:</p> <p>e) there are no fractures of any member, joint or component, and</p> <p>f) there is no loosening of joints intended to be rigid, and</p> <p>g) no major structural element is significantly deformed and the chair fulfils its functions after removal of the test loads</p> <p>h) after the test in Arm rest downward static load test with the forces and numbers of cycles according to the tables given on the last page, the arm rests shall show no fracture.</p>	<p>no risk of injury</p> <p>fulfilled</p> <p>fulfilled</p> <p>fulfilled</p> <p>fulfilled</p> <p>No fractures</p> <p>No loosening of rigid joints</p> <p>No visible deformation</p> <p>fulfilled</p>	<p>P</p> <p>P</p> <p>P</p> <p>P</p> <p>P</p> <p>P</p> <p>P</p> <p>P</p>



Table 2: Test sequence and parameters

Test	EN 1728	Loading	Level 1	Verdict
Combined seat and back static load test	7.3	Seat force	1.600 N, 10 times	P
		Back force	560 N, 10 times	P
Seat front edge static load test	7.4	Seat front edge	1.600 N, 10 times	P
Static load test of the footrest	7.8	Footrest	1.300 N, 10 times	P
Seat and back durability	7.9	Step 1: Force, N, at point A Cycles	1.500 120.000	P
		Step 2: Force, N, at point C Force, N, at point B Cycles	1.200 320 80.000	P
		Step 3: Force, N, at point J Force, N, at point E Cycles	1.200 320 20.000	P
		Step 4: Force, N, at point F Force, N, at point H Cycles	1.200 320 20.000	P
		Step 5 ^a : Force, N, at point D and G Cycles	1.100 20.000	P
Armrests durability	7.10	Force, N Cycles	400 60 000	P
Armrest downward static load test – central ^b	7.5	Force, N Cycles	750 5	P
Armrest downward static load test – central ^c		Force, N Cycles	900 5	P
^a In derogation to EN 1728:2012, 7.2.5 and 7.28 the loading point D shall be 150 mm to the right of point A and the loading point G shall be 150 mm to the left of point A ^b This test shall be carried out before the stability tests ^c This test shall be carried out after the stability tests				

Table 3: Loads, Masses and Cycles of stability tests:

Test description	Loads	Result	Cycles	Verdict
Overturning over the front corner	M ₁ = 30 kg	300 N	1	P
Overturning over the front edge	F ₁ = 600 N F ₂ = 20 N	F ₂ = 30 N	1	P
Overturning over the front edge for seating with footrest	F ₁ = 600 N F ₂ = 20 N	--	1	n.a.
Overturning over the side edge for seating without armrests	F ₁ = 600 N F ₂ = 20 N	F ₂ = 30 N	1	P
Overturning over the side edge for seating with armrests	F ₁ = 250 N F ₂ = 350 N F ₃ = 20 N	F ₃ = 35 N	1	P
Overturning backwards for seating without backrest inclination	F ₁ = 600 N F ₂ = 171 N	F ₂ ≥ 171 N	1	P
Overturning backwards for seating with backrest inclination	13 load discs	13 load discs	1	P

Table 4: Loads, Masses and Cycles of strength and durability tests:

Test description	Loads	Cycles	Verdict
Static load of the seat front edge	F ₁ = 1600 N	10	P
Combined static load test of the seat and backrest	F ₁ = 1600 N F ₂ = 560 N	10	P
Static load test of the footrest	F = 1300 N	10	n.a.
Durability test of the seat and backrest			
Step 1 — Load application point A	F = 1500 N	120000	P
Step 2 — Load application point C Load application point B	F = 1200 N F = 320 N	80000	P
Step 3 — Load application point J Load application point E	F = 1200 N F = 320 N	20000	P
Step 4 — Load application point F Load application point H	F = 1200 N F = 320 N	20000	P
Step 5 — Load application point D und G	F = 1200 N	20000	P
Durability test of the armrest	F = 400 N	60000	P
Test of armrests with static downwards loads	F = 750 N F = 900 N	5	P

Test characteristics/requirements	Test parameters/results	Verdict
<p>Information for use</p> <p>Each chair shall be accompanied by information for use in the language of the country in which it will be delivered to the end user. It shall contain at least the following details:</p> <p>a) Type of the chair: Type Ax, Type A, Type B or Type C;</p> <p>b) Information of the intended field of use;</p> <p>c) Instructions of all adjustment mechanism;</p> <p>d) Assembly instructions if applicable;</p> <p>e) instruction for the care and maintenance of the chair;</p> <p>f) if the chair is fitted with caster, information on the choice of castors in relation to the floor surface.;</p> <p>g) information for chairs with seat height adjustments with energy accumulators that only trained personnel may replace or repair seat height adjustment components with energy accumulators;</p> <p>Marking according to ProdSG § 6</p> <p>Durable marking of product with name and contact address of manufacturer or importer and the product designation.</p>	<p>User guide available</p> <p>Available</p> <p>Available</p> <p>Available</p> <p>Not applicable</p> <p>Product is self-explaining</p> <p>Available</p> <p>Available</p> <p>Available and fulfilled</p>	<p></p> <p>P</p> <p>P</p> <p>P</p> <p>n.a.</p> <p>n.a.</p> <p>P</p> <p>P</p> <p>P</p>

Page	Type of change
5,6,7,8	Additional information has changed and added



General note:

This report has been prepared for the titled project or named part thereof and should not be relied upon or used for any other project without an independent check being carried out as to its suitability and prior written authority of Intertek being obtained. Intertek accepts no responsibility or liability for the consequences of this document being used for a purpose other than the purposes for which it was commissioned. Any person using or relying on the document for such other purposes agrees, and will by such use or reliance be taken to confirm his agreement to indemnify Intertek for all loss or damage resulting therefrom. Intertek accepts no responsibility or liability for this document to any party other than the person by whom it was commissioned.

We would like to point out, that Intertek can't provide legally binding assessments referring to isolated cases. The individual legal advice in Germany is reserved to the legal advisory professions and a binding interpretation is subject to the court of justice.

Copying excerpts or otherwise reproducing parts of the test report is permitted only with the consent of the laboratory accepting the order. This report pertains only to the test item(s).

All testing requests are subject to our Terms and Conditions available on www.intertek.com.

END OF REPORT

